



Warrick® Series 67

Intrinsically Safe Multi-Function Control Installation and Operation Bulletin

Table of Contents

Page 3	Installation Instructions: Safe Sensing Circuits- General Information <ul style="list-style-type: none">- Mounting Location- Wiring
Page 4	Installation Instructions: Intrinsically Safe Sensing Circuits <ul style="list-style-type: none">- Grounding- Sensor Wiring
Page 5	Installation Instructions: Intrinsically Safe Sensing Circuits
Page 6	Installation Instructions: Intrinsically Safe Sensing Circuits <ul style="list-style-type: none">- Alarm Channel Wiring- Alternation Circuitry
Page 7	Installation: High Voltage Circuits <ul style="list-style-type: none">- AC Supply- Grounding- Output Contacts
Page 8	Control Diagram
Page 9	Technical Information <ul style="list-style-type: none">- Specification- Ordering Information- Module Replacement
Page 10	Technical Information <ul style="list-style-type: none">- Module Replacement
Page 11	Operation Instructions <ul style="list-style-type: none">- Single Level Service: Contact Operation- Single Level Service: Alarm Functions
Page 12	Operation Instructions <ul style="list-style-type: none">- Differential Level Service: Simplex
Page 13	Operation Instructions <ul style="list-style-type: none">- Differential Level Service: Duplex
Page 14	General Control Information
Page 15	Sample Wiring Diagram

Notes:

Installation: Intrinsically Safe Sensing Circuits

This bulletin should be used by experienced personnel as a guide to the installation of the series 67. Selection or installation of equipment should always be accompanied by competent technical assistance. We encourage you to contact Gems Sensors or its local representative if further information is required.

IMPORTANT: BEFORE PROCEEDING TO INSTALL AND WIRE THE SERIES 67 CONTROL, READ AND THOROUGHLY UNDERSTAND THESE INSTRUCTIONS.

When installing according to these instructions, this device provides intrinsically safe sensing circuits for interface into Class I; Groups C & D, Class II; Groups E, F, & G and Class III; Hazardous Areas. Electrical equipment connected to associated apparatus should not exceed maximum ratings marked on product.

MOUNTING LOCATION

The control must be situated in a non-hazardous area where an explosive atmosphere will not exist at any time; otherwise, it must be mounted in a suitable U.L. approved explosion-proof enclosure with suitable U.L. approved explosion-proof seals.

WIRING: GENERAL INFORMATION

1. Intrinsically safe wiring must be kept separate from non-intrinsically safe wiring.
2. Intrinsically safe and non-intrinsically safe wiring may occupy the same enclosure or raceway if they are at least 2 inches (50mm) apart and separately tied down. Inside panels, field wiring terminals for intrinsically safe circuits must be separated by at least 2 inches (50 mm) from non-intrinsically safe wiring.
3. Wire the control device(s) to the Series 67 relay as shown in figure 1. A separate rigid metallic conduit should be used to enclose the conductors of the intrinsically safe control circuit.
4. An approved seal should be used at the point where the intrinsically safe control circuit wiring enters the hazardous area.

For intrinsically safe output wiring use #14 or #16 AWG type MTW or THHN wire. By using these wire types in conjunction with the following distance recommendations, you will not exceed the maximum capacitance for field wiring. Use Table 1 as a guide for maximum wire runs.

Table 1

Model Number	Sensitivity	Distance
67AXXA	4.7K Ohms	4,000 Feet
67BXXA	10K Ohms	2,400 Feet
67CXXA	26K Ohms	1,200 Feet
67DXXA	50K Ohms	600 Feet
67EXXA	100K Ohms	300 Feet

Installation: Intrinsically Safe Sensing Circuits

GROUNDING:

The four mounting holes on the Series 67 provide an electrical connection for earth grounding between the control's internal solid state circuitry and the enclosure chassis. To insure proper grounding, use only metal screws and lock washers when mounting this control. Terminal G on the supply line/load side terminal strip is a redundant system ground terminal and must be connected to earth ground buss of the control's AC supply line feeder.

Note:

1. Intrinsically safe terminals can be connected to any non-energy generating or storing switch device such as a pushbutton, limit or float type switch or any Warrick electrode and fitting assembly.
2. To prevent electrical shock from supply line/load side powered connections, the Series 67 should be mounted in a tool accessible enclosure of proper NEMA rated integrity.
3. For U.L. 913 Listed panels, a metallic partition may be necessary to provide adequate spacing between non-intrinsically safe and intrinsically safe wiring and /or terminals.
4. For additional guidance on "Hazardous Location Installation" and "Intrinsically Safe Devices", consult ANSI/ISA standard RP 12-6 or NEC articles 500-516 and local codes.

SENSOR WIRING

The Series 67 control has four independent intrinsically safe channels, which can be connected to different types of sensors including floats, conductance probes, pressure switches and other non-powered contacts or sensors. The connections of the sensors to the terminals will not vary with normally open or closed sensors. However, the Inverse/Direct DIP switches must be set to the proper mode for each channel to achieve the correct operation. Consult tables 2 and 3 for the proper DIP switch setting for various sensors and functions.

The following sections cover the intrinsically safe sensor connections for single and differential level service.

SINGLE LEVEL SERVICE:

All four channels can be used for single level service. Each channel is independent and can be used for its own single point function. However, only channels 3 and 4 have the alarm bell and silence capabilities. Consult the alarm sections for more information regarding the installation and operation of the alarm circuitry. Table 2 covers the sensor style to terminal connections for all four channels.

Table 2

Sensor Style	Terminal Connections	DIP Switch Settings
Normally Open: Closes on Alarm Condition	Channel 1 - HS1 & G* Channel 2 - HS2 & G* Channel 3 - S3 & G Channel 4 - S4 & G	Inverse Mode - Up Position
Normally Open: Opens on Alarm Condition	Channel 1 - HS1 & G* Channel 2 - HS2 & G* Channel 3 - S3 & G Channel 4 - S4 & G	Direct Mode - Down Position
Normally Closed: Closes on Alarm Condition	Channel 1 - HS1 & G* Channel 2 - HS2 & G* Channel 3 - S3 & G Channel 4 - S4 & G	Inverse Mode - Up Position
Normally Closed: Opens on Alarm Condition	Channel 1 - HS1 & G* Channel 2 - HS2 & G* Channel 3 - S3 & G Channel 4 - S4 & G	Direct Mode - Down Position

* **Note:** Channels 1 & 2 cannot activate the alarm bell contacts and do not have the silence/acknowledge capabilities

Installation: Intrinsically Safe Sensing Circuits

DIFFERENTIAL LEVEL SERVICE:

Channels 1 and 2 are designed to provide differential on/off points to control pumps, solenoid valves or other equipment. These channels can also be used in single level service for alarms and cutoffs, however the control's built-in silence circuitry and bell contacts cannot be used. Consult the Alarm section for more information.

When channels 1 and 2 are used for differential level service, the associated sensors must be normally open. The Inverse/Direct DIP switches must also be set to the proper mode for each channel to achieve the correct operation. Table 3 gives the correct sensor to terminal connections and DIP switch settings for various applications.

FOR APPLICATIONS THAT DO NOT REQUIRE DUPLEX ALTERNATION, A JUMPER WIRE MUST BE PLACED FROM THE "G" TO "1-2" TERMINAL.

Table 3

Application	Sensor Contact Style	Sensor Terminal Connections	DIP Switch Setting
Simplex Pump-Down or Solenoid Valve Drain**	Normally Open - Closes on Rising Level	Start Pump / Open Valve - HS1 & G* Stop Pump / Close Valve - LS1 & G*	Direct - Down Channels 1 or 2
Simplex Pump-Up or Solenoid Valve Fill	Normally Open - Closes on Rising Level	Start Pump / Open Valve - LS1 & G* Stop Pump / Close Valve - HS1 & G*	Inverse - Up Channels 1 or 2
Duplex Pump-Down - Common Pump Stop	Normally Open - Closes on Rising Level	Duty Pump Start - HS1 & G* Standby Pump Start - HS2 & G* Duty and Standby Pump Stop - LS1 & G* Jumper - LS1 and LS2	Direct - Down Channels 1 or 2
Duplex Pump-Up - Common Pump Stop	Normally Open - Closes on Rising Level	Duty Pump Start - LS1 & G* Standby Pump Start - LS2 & G* Duty and Standby Pump Stop - HS1 & G* Jumper - HS1 and HS2	Inverse - Up Channels 1 or 2
Duplex Pump-Down - Separate Pump Stops	Normally Open - Closes on Rising Level	Duty Pump Start - HS1 & G* Standby Pump Start - HS2 & G* Duty and Standby Pump Stop - LS1 & G* Jumper - LS2 and G*	Direct - Down Channels 1 or 2
Duplex Pump-Up - Separate Pump Stops	Normally Open - Closes on Rising Level	Duty Pump Start - LS1 & G* Standby Pump Start - LS2 & G* Duty and Standby Pump Stop - HS1 & G* Jumper - HS2 & G*	Inverse - Up Channels 1 or 2

*** Note 1:** If conductance probes are being used, only one "G" connection is required. Terminal "G" must be grounded to the vessel if metallic. If the electrode fitting being used has a metallic body and is supported directly upon a metallic vessel, the ground connection is facilitated by securing that end of the ground connector beneath the head of one of the screws which fasten the terminal housing to the body of the fitting. When the vessel is non-metallic, terminal "G" must be connected to an additional electrode of length equal to or longer than, the longest electrode. If wire suspension electrodes are being used, more than one Ground/Reference probe may be required.

**** Note 2:** This setup is based on the use of a Normally Closed (N.C.) solenoid valve that energizes to open when power is applied to the coil circuit.

Installation: Intrinsically Safe Sensing Circuits

ALARM CHANNEL WIRING:

SILENCE CIRCUITRY:

A normally open pushbutton is required for the Series 67's alarm silence circuitry. The N.O. pushbutton must be connected to the "SIL" and "G" terminals. For more information about the operation of the silence circuitry consult the Alarm Operation section on page 11. **NOTE: THE SILENCE PUSHBUTTON IS CONNECTED TO THE INTRINSICALLY SAFE CIRCUITRY. THEREFORE THE PUSHBUTTON AND ITS ASSOCIATED WIRING SHOULD BE SEPARATED FROM THE NON-INTRINSICALLY SAFE WIRING AND DEVICES. CONSULT GENERAL WIRING INFORMATION FOR MORE INFORMATION.**

ALARM DIP SWITCHES:

The alarm DIP switches for channels 3 and 4 can be set to enable the bell contacts for one or both alarm channels. However, this does not disable the alarm contact for that channel. Table 4 covers the DIP switch settings for various alarm conditions.

Table 4

DIP Switch Settings	Bell Contact Status
3 Off - Down	Channel 3 - Off - Disabled
4 Off - Down	Channel 4 - Off - Disabled
3 On - Up	Channel 3 - On - Enabled
4 Off - Down	Channel 4 - Off - Disabled
3 On - Up	Channel 3 - On - Enabled
4 On - Up	Channel 4 - On - Enabled
3 Off - Down	Channel 3 - Off - Disabled
4 On - Up	Channel 4 - On - Enabled

ALTERNATION CIRCUITRY

AUTO OR MANUAL:

Series 67's built-in alternator can be used to automatically alternate between two loads controlled by channels 1 and 2. However, the automatic alternation may be by-passed to become a manual operation. This can be accomplished with the use of jumper wires or a three position switch connected to the 2-1, 1-2 and "G" terminals. Table 5 covers the jumper connections for manual alternation. Refer to figure 1 for more wiring information on the wiring of the three position selector switch. **NOTE: THE MANUAL ALTERNATION CIRCUITRY IS CONSIDERED INTRINSICALLY SAFE. THEREFORE THE SELECTOR SWITCH, JUMPER WIRES AND THEIR ASSOCIATED WIRING SHOULD BE SEPARATED FROM NON-INTRINSICALLY SAFE WIRING DEVICES. CONSULT GENERAL WIRING INFORMATION FOR MORE INFORMATION ON INTRINSIC SAFETY.**

Table 5

Alternation Status	Jumper Required	LED Status Pump-Down*	LED Status Pump-Up*
Automatic*	None	Either	Either
Manual 2-1	Terminals 1-2 to "G"	No. 1**	No. 1**
Manual 2-1*	Terminals 2-1 to "G"	No. 2**	No. 2**

Notes

* For non-alternation applications jumper 1-2 to "G"

** The position of the 1-2 and 2-1 indicating LED's is dependent on the application. The position changes for pump-up or pump-down. Consult control diagram figure 6-1 for more information.

Installation: High Voltage Circuits

A.C. SUPPLY:

Connect the incoming supply HOT lead to the L1 terminal, NEUTRAL lead to the L2 terminal and EARTH GROUND lead to the "G" Terminal. Note: the incoming power supply should have the same electrical characteristics as indicated on the control's label.

GROUNDING

Terminal "G" on the supply line/load side terminal strip is a redundant system ground terminal and must be connected to the earth ground buss of the panel's AC supply line feeder.

OUTPUT CONTACTS

Channels 1-4: Each channel has a dedicated non-powered contacts. These can be either Form C or Form A & B depending on the model. These contacts will change state when their respective channel activates. In DIRECT mode the relay will energize and the contacts will change state when the probe circuit sensor closes. In INVERSE mode the relay will energize and contacts will change state upon power up. The channel will then de-energize and return the contacts to their shelf state when the probe circuit sensor closes.

Form C- This contact configuration consists of one (1) Normally Open contact and one (1) Normally Closed contact. There are three terminals for electrical connections, N.O., N.C. and Common. Each terminal will accept up to two (2) #14 AWG wires

Form A & B: This contact configuration consists of one (1) Normally Open contact and one (1) Normally Closed contact which are electrically isolated from each other. There are two terminals for each contact. Each will accept one (1) # 14 AWG wire.

Alarm Bell: The alarm bell contacts are non-powered Form C construction. This contact configuration consist of consists of one (1) Normally Open contact and one (1) Normally Closed contact. There are three terminals for electrical connections, N.O., N.C. and Common. Each terminal will accept up to two (2) #14 AWG wires

When the output contacts are used to drive loads they should be wired in series with the load. This series branch circuit should then be connected across a power source compatible with the load. See figure 1.

Figure 1

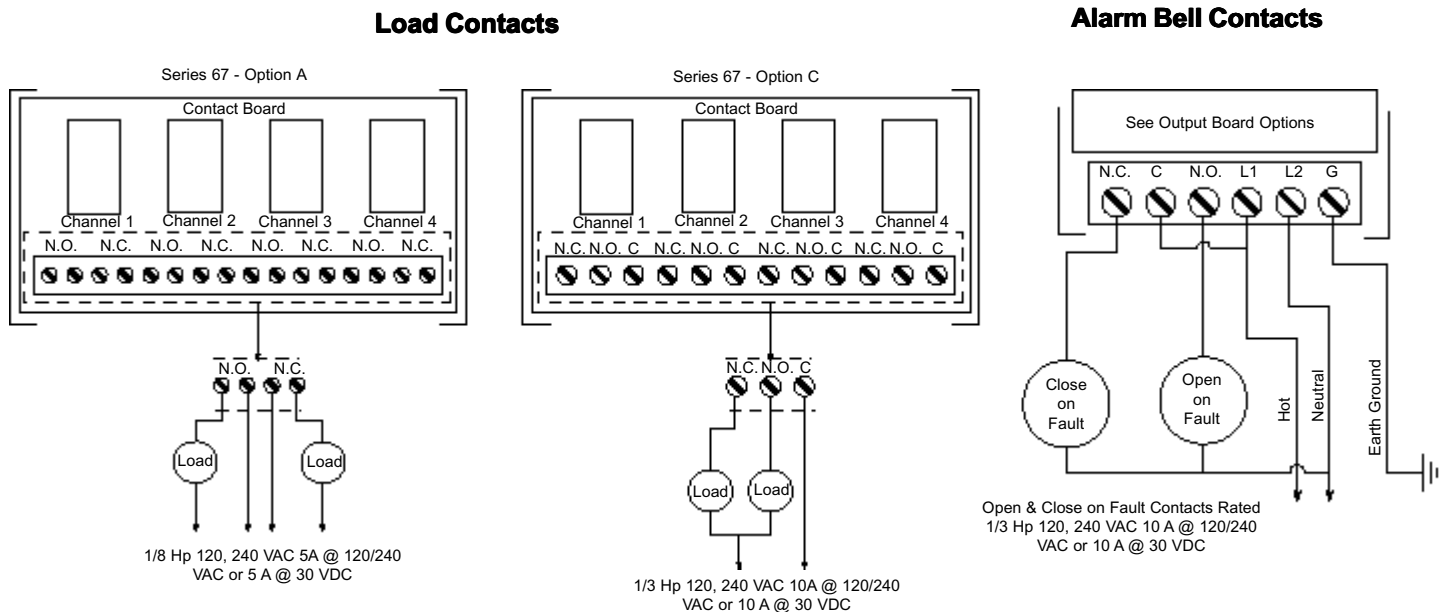

Control Diagram

Figure 2

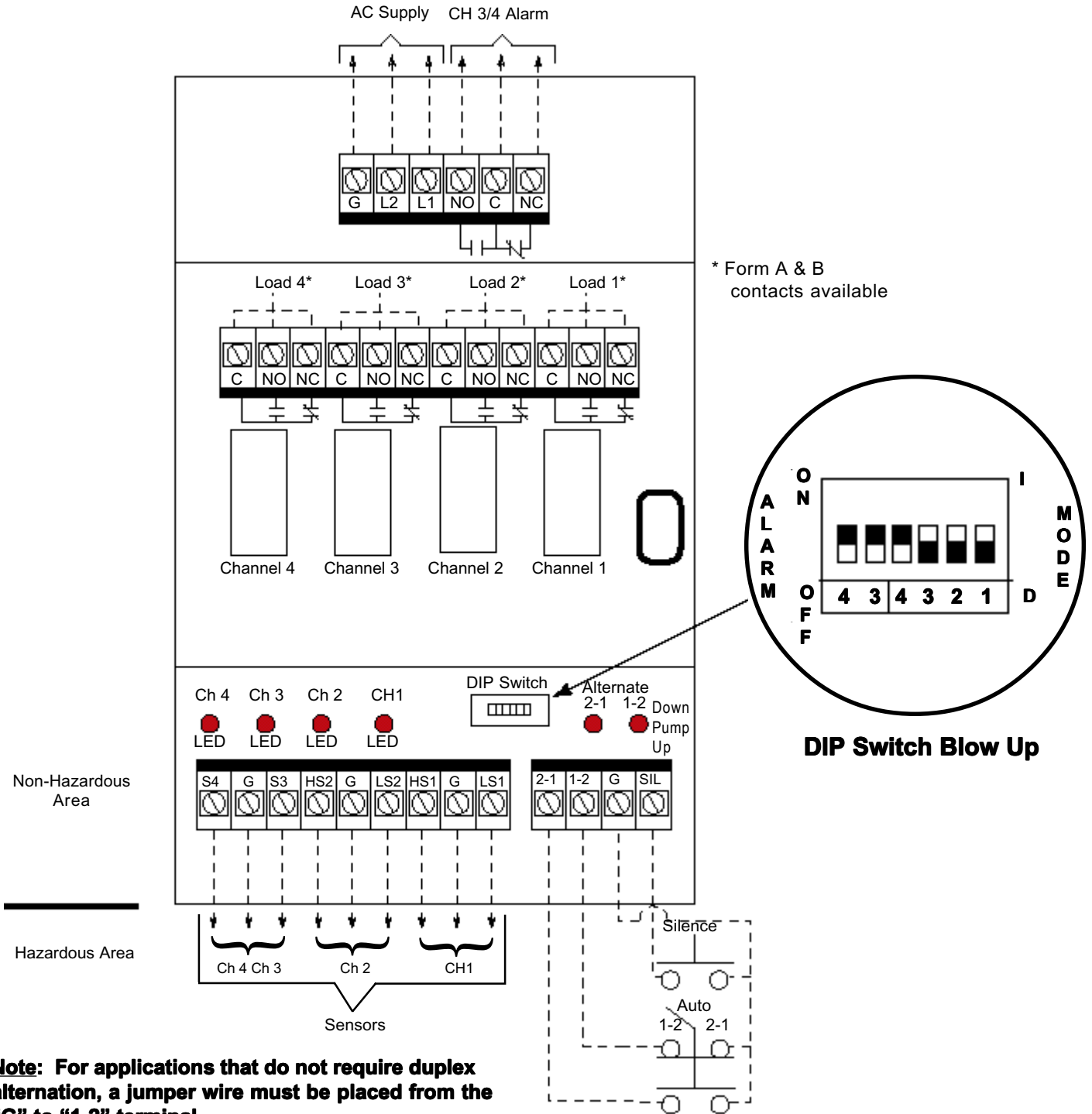

Technical Information

SPECIFICATIONS

Contact Design: Standard SPDT (1 form C): one normally open (N.O.) and one normally closed (N.C.), non powered contacts Contact Ratings for each channel. Optional 1 Form A (N.O.) and 1 Form B (N.C.) isolated

Load Contact Ratings: Standard Form C- 10A @ 120/240 VAC resistive and 30 VDC resistive, 1/3 Hp @ 120/240 VAC. Optional Form A & B - 5A @120/240 VAC and 30 VDC resistive, 1/8 Hp @ 120/240 VAC.

Bell Contacts: 1 Form C (N.O.), N.C., C)

Bell Contact Ratings: 10A @ 120/240 VAC and 30 VDC resistive, 1/3 Hp @ 120/240 VAC

Contact Life: Mechanical - 10 million operations. Electrical - 1,000,000 operations minimum at rated load.

Primary Voltage: 120 or 240 VAC models + 10% - 15%, 50/60 Hz.

Supply Current: Relays energized - 60ma @ 120 VAC, 30ma @ 240 VAC

Secondary Circuit: 12 VAC RMS voltage on probes, 6ma current RMS.

Sensitivity: Models operate from 4700-100,000 ohms maximum specific resistance

Temperature: -40° to 150° F Ambient

Electronics Module: Solid state components enclosed in a black nylon housing

Terminals: Standard Form C removable terminal strip containing a size 4 pan head screw with a clamping plate. Will accept up to two (2) #14 AWG wires per terminal. Optional Form A & B relay board will accept up to one (1) #14 AWG wire per terminal. Use copper (60-75° C) wire only. Torque to 20 inch pounds.

Listings: U.L. Intrinsically Safe (UL 913) File Number: E87112

ORDERING INFORMATION

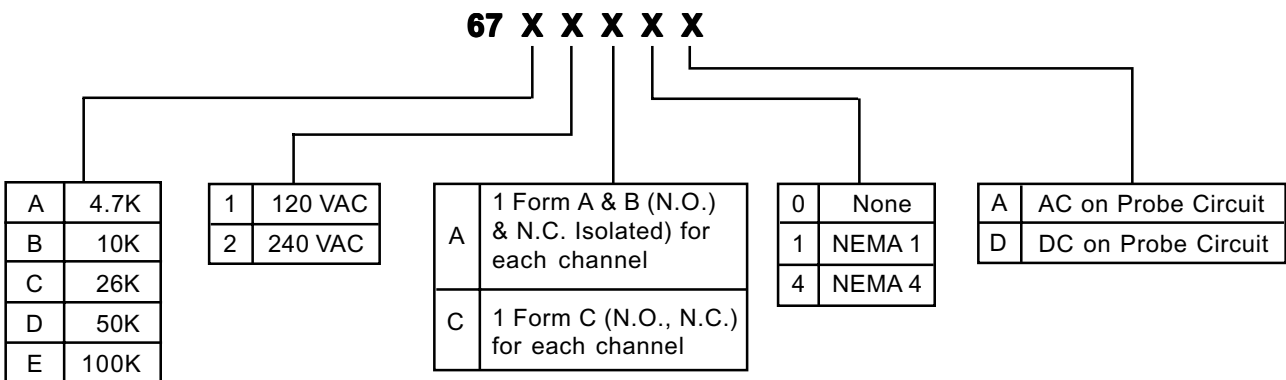

MODULE REPLACEMENT

If the electronic module needs to be replaced:

1. Turn off power to the control and load devices
2. Remove the metal partition located across the center of the module (when required).
3. Remove all field wiring terminal blocks from the electronic module. **The field wires do not need to be removed from the terminal blocks.** The terminal blocks separate from the board as show in figure 8-1.
4. Remove the four (4) retaining screws from the base of the electronic module. The module can now be removed from the control panel.
5. Install a new module and reinstall all of the terminal blocks.
6. Reinstall the metal partition (when required).
7. Set all DIP switches according to previous instructions.

Technical Information: Module Replacement

Diagram 3

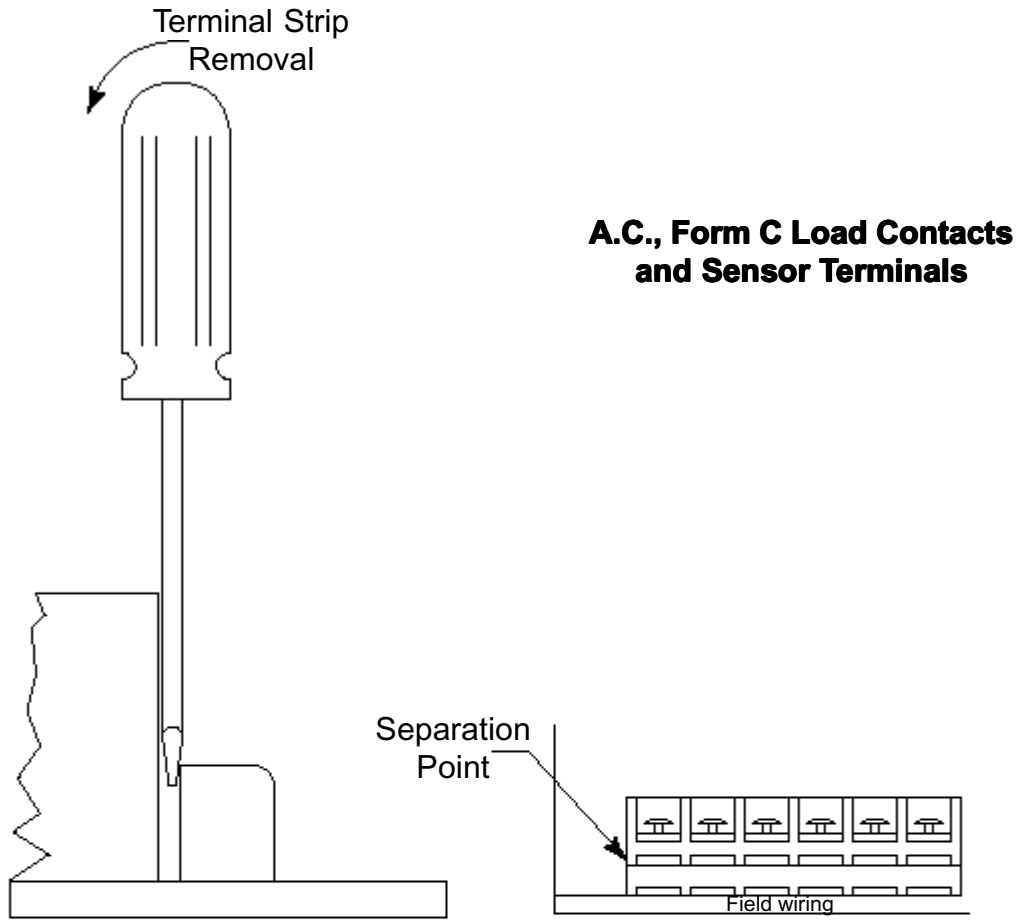

Form A & B Contacts

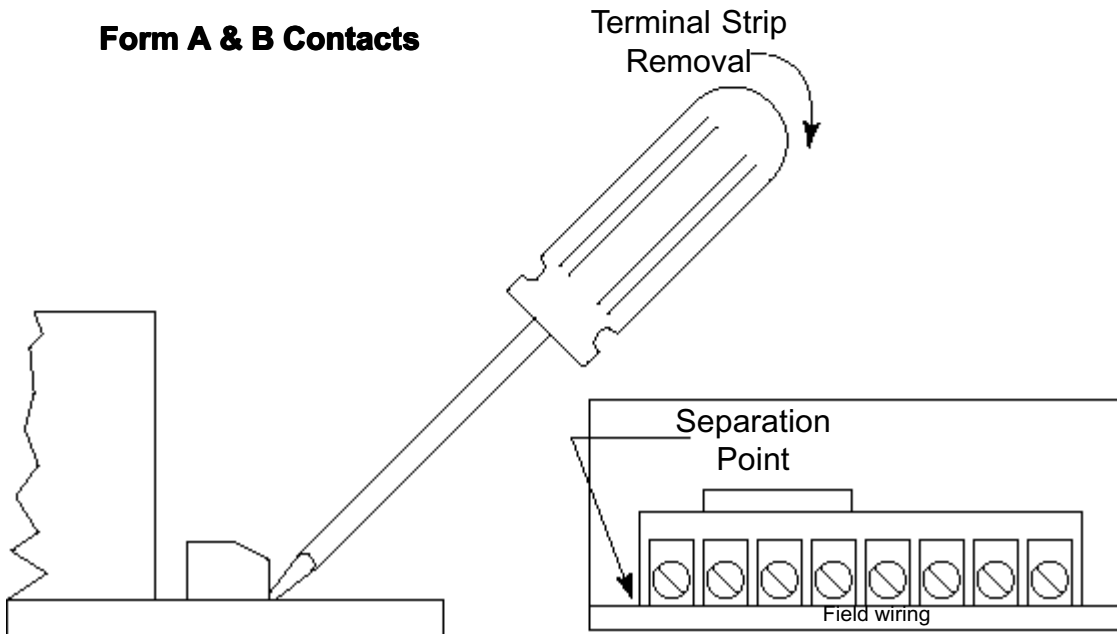

Operation Instructions

The Series 67 multi-function control can be used for many different applications including: pump control, solenoid valve control and alarm activation. The following instructions cover the most common applications. If your application is not included, contact Gems Sensors or our authorized representative in your area for assistance.

The operating instructions are broken up into two general categories: SINGLE and DIFFERENTIAL LEVEL SERVICE. The alarm functions are covered under the SINGLE LEVEL SERVICE heading while the pumping and solenoid valve functions are covered under the DIFFERENTIAL LEVEL SERVICE heading.

SINGLE LEVEL SERVICE: CONTACT OPERATION

LOAD CONTACTS: CHANNELS 1-4

The activation of these contacts is dependent upon the type of sensor (normally open or closed) and the mode of operation (direct or inverse). The table 6 gives the sensor activation condition, DIP switch settings, contact status and LED status for various applications and sensors.

Table 6

Application	Warrick Sensor	Sensor" Alarm Activation Condition	DIP Switch Setting	Relay Status Upon Alarm	LED Status Upon Alarm
High Level Alarm Normally Open Float	FE - Reed Switch Float for M Tilt Float	Closes on Rising Level	Inverse UP "I"	De-Energized	ON
High Level Alarm Normally Closed Float	FE - Reed Switch Float for M Tilt Float	Opens on Rising Level	Direct DOWN "D"	De-Energized	OFF
Low Level Alarm Normally Open Float	FE - Reed Switch Float for M Tilt Float	Opens on Falling Level	Direct DOWN "D"	De-Energized	OFF
Low Level Alarm Normally Closed Float	FE - Reed Switch Float for M Tilt Float	Closes on Falling Level	Inverse UP "I"	De-Energized	ON
High Level Alarm Conductance Probes	3R, 3T, 3W, 3Y, 3H or 3S	Probes in Contact with Conductive Liquid	Invers UP "I"	De-Energized	ON
Low Level Alarm Conductance Probes	3R, 3T, 3W, 3Y, 3H or 3S	Probes not in Contact with Conductive Liquid	Direct DOWN "D"	De-Energized	OFF
UNKNOWN SENSOR Normally Open		Closes on Fault	Inverse UP "I"	De-Energized	ON
UNKNOWN SENSOR Normally Closed		Opens on Fault	Direct DOWN "D"	De-Energized	OFF

SINGLE LEVEL SERVICE: ALARM FUNCTIONS

BELL CONTACTS:

Under NORMAL operating conditions the alarm bell relay is held energized. The relay will de-energize to activate an alarm device when an abnormal condition exists on either channels 3 and/or 4. Either one or both alarm bell circuits can be disabled by adjusting the alarm DIP switches. Consult table 4 for more information on the bell DIP switch settings.

SILENCE CIRCUITRY:

Should an abnormal condition exist on either channels 3 and/or 4 the normally closed (N.C.) alarm bell relay contacts will close, activating an alarm device. The N.C. alarm bell contacts can be returned to their normal state (open) silencing the alarm, by depressing a normally open pushbutton connected to the "SIL" and "G" terminals. This will NOT affect the load contacts for channels 3 or 4 as they act independent from the alarm bell contacts.

Operation Instructions

DIFFERENTIAL LEVEL SERVICE:

The following operating instructions are based on correct DIP switch settings and sensor types. Any deviation from these requirements may result in incorrect system operations. Consult table 7 for further instructions.

Table 7

Application	Warrick Sensor	DIP Switch Setting	Activation Condition	Contact Status	LED Status Sensor Closed
Simplex Pump-Down or Solenoid Valve Drain	Normally Open: F, M, FE, FOE 3R, 3T, 3W, 3Y, 3H or 3S	Direct "Down"	Sensor Closes on Rising Level	N.O. - Closes N.C. - Opens	ON
Simplex Pump-Up or Solenoid Valve Fill	Normally Open: F, M, FE, FOE 3R, 3T, 3W, 3Y, 3H or 3S	Inverse "Up"	Sensor Closes on Rising Level	N.O. - Opens N.C. - Closes	OFF
Duplex Pump-Down - Common Pump Stop	Normally Open: F, M, FE, FOE 3R, 3T, 3W, 3Y, 3H or 3S	Direct "Down"	Sensor Closes on Rising Level	N.O. - Closes N.C. - Opens	ON
Duplex Pump-Up - Common Pump Stop	Normally Open: F, M, FE, FOE 3R, 3T, 3W, 3Y, 3H or 3S	Inverse "Up"	Sensor Closes on Rising Level	N.O. - Opens N.C. - Closes	OFF
Duplex Pump-Down - Separate Pump Stop	Normally Open: F, M, FE, FOE 3R, 3T, 3W, 3Y, 3H or 3S	Direct "Down"	Sensor Closes on Rising Level	N.O. - Closes N.C. - Opens	ON
Duplex Pump-Up - Separate Pump Stop	Normally Open: F, M, FE, FOE 3R, 3T, 3W, 3Y, 3H or 3S	Inverse "Up"	Sensor Closes on Rising Level	N.O. - Opens N.C. - Closes	OFF

DIFFERENTIAL LEVEL SERVICE: SIMPLEX

Simplex Pump Down- Should the level rise to the PUMP START sensor the N.O. load contacts will close starting the pump. The pump will remain running until the level recedes below the PUMP STOP sensor and the load contacts open.

Simplex Pump UP- Should the level recede below the PUMP START sensor the N.O. load contacts will close starting the pump. The pump will remain running until the level rises to the PUMP STOP sensor and the load contacts open.

Solenoid Valve Drain- Should the level rise to the VALVE OPEN sensor the N.O. load contacts will close energizing the normally closed valve to open. The valve will remain open until the level recedes below the VALVE CLOSE sensor and the load contacts open

Solenoid Valve Fill- Should the level recede below the VALVE OPEN sensor, the N.O. load contacts will close energizing the normally closed valve to open. The valve will remain open until the level rises to the VALVE CLOSE sensor and load contacts open.

Operation Instructions

DIFFERENTIAL LEVEL SERVICE: DUPLEX PUMP DOWN WITH ALTERNATION

Common Pump Stop- The pumps will alternate each cycle with the duty pump starting when the level rises to the DUTY PUMP START sensor and stops when the level recedes below the PUMP(S) STOP sensor.

If the duty pump fails or cannot meet the demand of the system and the level rises to the STANDBY PUMP START sensor, the standby pump will be started and will continue in operation until the level recedes below the PUMP(S) STOP sensor.

Separate Pump Stops- The pumps will alternate each cycle with the duty pump starting when the level rises to the DUTY PUMP START sensor and stops when the level recedes below the DUTY PUMP STOP sensor.

If the duty pump fails or cannot meet the demand on the system and the level rises to the STANDBY PUMP START sensor, the standby pump will be started and will continue in operation until the level recedes below the STANDBY PUMP STOP sensor.

DIFFERENTIAL LEVEL SERVICE: DUPLEX PUMP UP WITH ALTERNATION

Common Pump Stop- The pumps will alternate each cycle with the duty pump starting when the level recedes below the DUTY PUMP START sensor and stops when the level rises to the PUMP(S) STOP sensor.

If the duty pump fails or cannot meet the demand of the system and the level recedes to the STANDBY PUMP START sensor, the standby pump will be started and will continue in operation until the level rises to the PUMP(S) STOP sensor.

Separate Pump Stops- The pumps will alternate each cycle with the duty pump starting when the level recedes to the DUTY PUMP START sensor and stops when the level rises to the DUTY PUMP STOP sensor.

If the duty pump fails or cannot meet the demand on the system and the level recedes to the STANDBY PUMP START sensor, the standby pump will be started and will continue in operation until the level rises to the STANDBY PUMP STOP sensor.

DIFFERENTIAL LEVEL SERVICE: DUPLEX PUMP DOWN WITHOUT ALTERNATION

Same operation as above disregarding the alternation sequence. Use appropriate jumper to determine manual pump start sequence. Refer to table 5 for the manual alternation jumper information.

DIFFERENTIAL LEVEL SERVICE: DUPLEX PUMP UP WITHOUT ALTERNATION

Same operation as above disregarding the alternation sequence. Use appropriate jumper to determine manual pump start sequence. Refer to table 5 for the manual alternation jumper information.

General Control Information

Figure 4

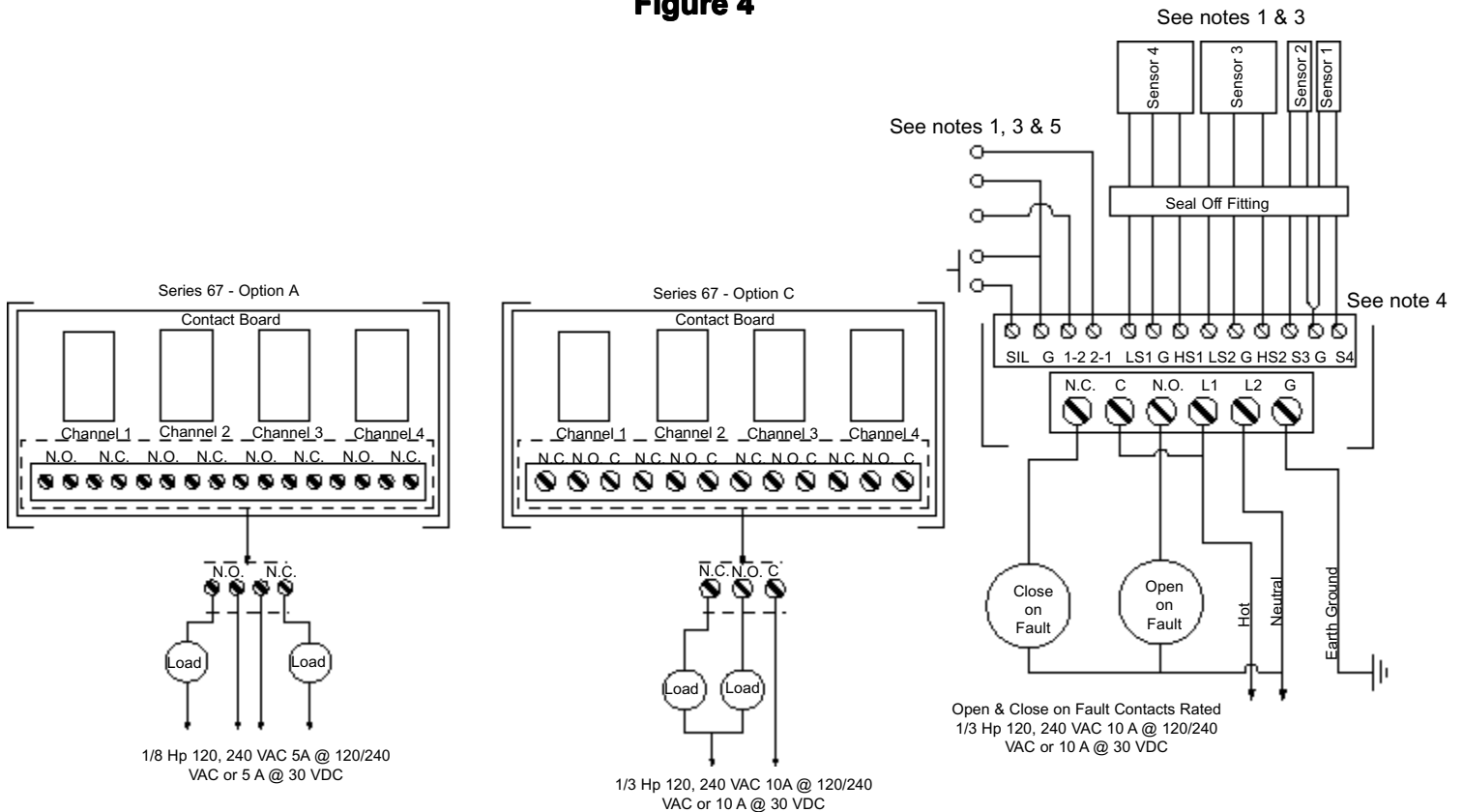

Notes:

1. **All intrinsically safe wiring must be installed in accordance with article 504 of the National Electric Code, publication ANSI/NFPA 70 or CEC, Part 1 as applicable.**
2. **Grounding- The four mounting holes on the Series 67 provide an electrical connection for earth grounding between the controls internal solid state circuitry and the enclosure chassis. To insure proper grounding, use only metal screws and lock washers when mounting the control.**

Terminal "G" on the supply line/load side terminal strip is a redundant system ground terminal and must be connected to the earth ground buss of the controls A.C. supply line feeder. The resistance between the system ground terminals and the earth ground buss must be less than 1 ohm.

To prevent electrical shock from supply line/load side powered connections, the Series 67 should be mounted in a metal enclosure of proper NEMA integrity.
3. **The maximum total length of all of the intrinsically safe wiring (of each conductor) shall not exceed an accumulative value of 16,000 feet, excluding any ground wiring.**
4. **The intrinsically safe terminals of the Series 67 can be connected to any non-energy generating or storing switch device such as a push button, a limit or float type switch or any of Warrick's electrode fitting assemblies.**
5. **When wiring alternation and bell silence switches, the switches and wiring must be separated from non-intrinsically safe circuits and wired in accordance with article 504 of the National Electric Code, publication ANSI/NFPA 70 or CEC, Part 1 as applicable.**

Sample Wiring Diagram

Figure 5

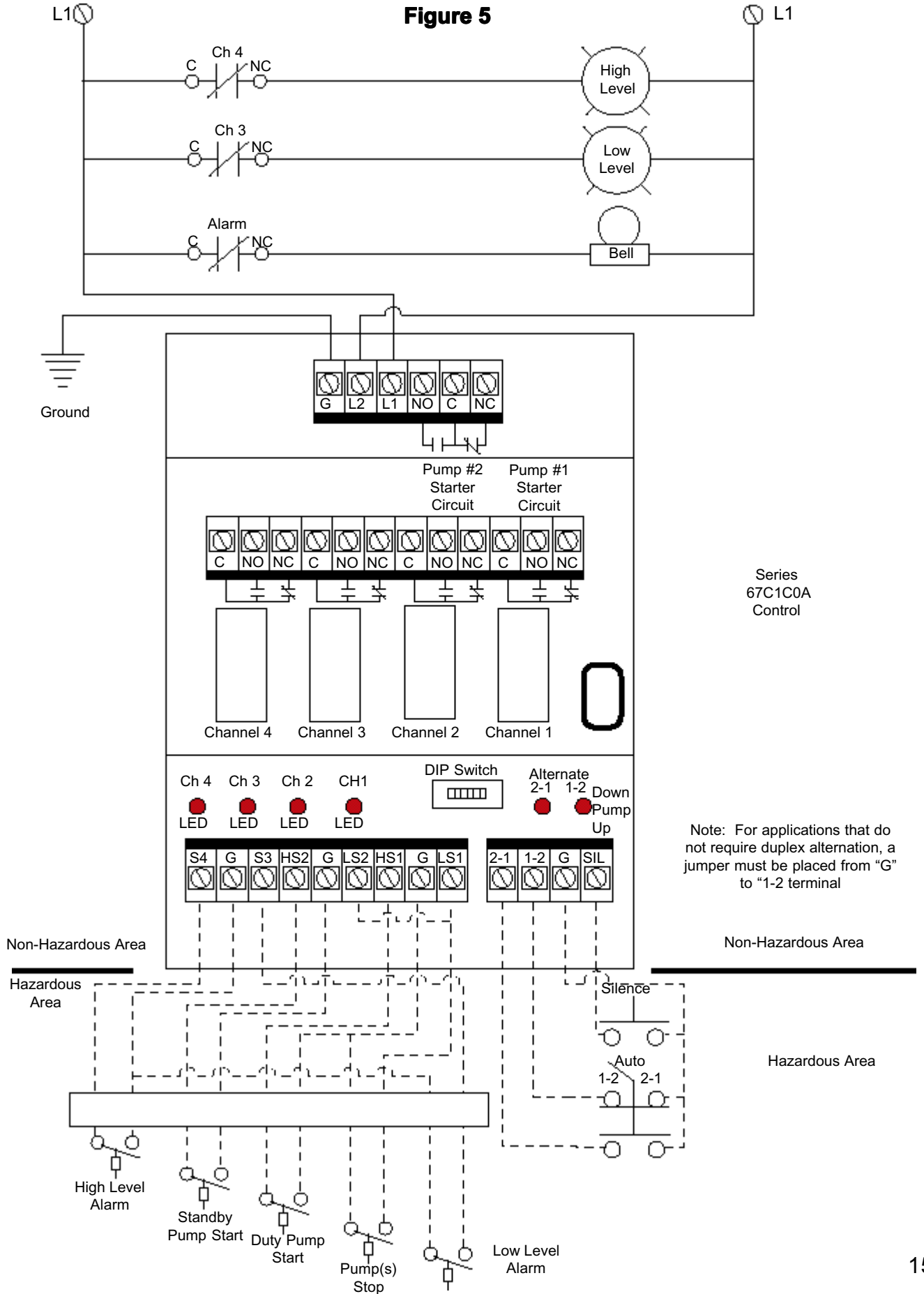

Notes:



Gems Sensors Inc.
One Cowles Road
Plainville, CT 06062-1198
Tel: 860-793-4579
Fax: 860-793-4580